

THIS DOCUMENT IS THE PROPERTY OF FABCO INDUSTRIES AND IS CONVEYED WITH THE EXPRESS CONDITION THAT IT AND THE INFORMATION CONTAINED IN IT ARE NOT TO BE USED, DISCLOSED, OR REPRODUCED IN WHOLE OR IN PART FOR ANY PURPOSE WITHOUT THE EXPRESS WRITTEN CONSENT OF FABCO INDUSTRIES, AND THAT NO RIGHT IS GRANTED TO DISCLOSE OR SO USE ANY INFORMATION CONTAINED IN SAID DOCUMENT.

REVISIONS			
REV	DESCRIPTION	DATE	APPROVED
D	ECN9731-1-000D	5/26/11	

NOTES:

1. WEIGHT (EMPTY): 55 LB MAX, NO CARTRIDGES
2. MATERIAL:
 - A) ADJUSTABLE FLANGE AND DEFLECTOR: ALUMINUM ALLOY 6063-T6
 - B) SPLASH GUARD: NEOPRENE RUBBER, 80 DUROMETER
 - C) BASIN (PLASTIC): POLYPROPYLENE POLYETHYLENE COPOLYMER
 - D) CORNER FILLER: ALUMINUM ALLOY: 5052-H32
 - E) SUPPORT HARDWARE: CRES 300 SERIES
3. PERFORMANCE CHARACTERISTICS (TYP):
 - A) DEBRIS CAPACITY: 6.9 CU-FT
 - B) FILTERED FLOW RATE (CLEAN STANDARD CARTRIDGE): 230 GPM (0.51 CFS)
 - C) PRIMARY BYPASS FLOW RATE: 2064 GPM (4.6 CFS)
 - D) SECONDARY BYPASS FLOW RATE: 164 GPM (0.37 CFS)
 - E) TOTAL BYPASS FLOW RATE: 2228 GPM (5.0 CFS)
4. CLEAR OPENING RANGE (0.5 INCH INCREMENTS):
 - A) MINIMUM SIZE: 23.0 X 45.0
 - B) MAXIMUM SIZE: 28.0 X 50.0
5. RECOMMENDED MINIMUM VAULT DEPTH 2-IN BELOW CARTRIDGE
6. TYPICAL INSTALLATION: REMOVE STORM GRATE, MEASURE CATCH BASIN FRAME CLEAR OPENING AND ADJUST FLANGES TO REST ON GRATE SUPPORT LEDGE. INSTALL STORMBASIN INSERT WITH RUBBER SPLASH GUARD EXTENDING INTO THE CURB-BOX AND VERIFY THE ADJUSTABLE FLANGES ARE SECURELY RESTING ON THE GRATE SUPPORT LEDGES. INSTALL CORNER FILLER PIECES. REINSTALL THE STORM GRATE DIRECTLY ON THE STORMBASIN SUPPORT FLANGES.
7. USE ONLY WITH FABCO REPLACEABLE MEDIA CARTRIDGES.

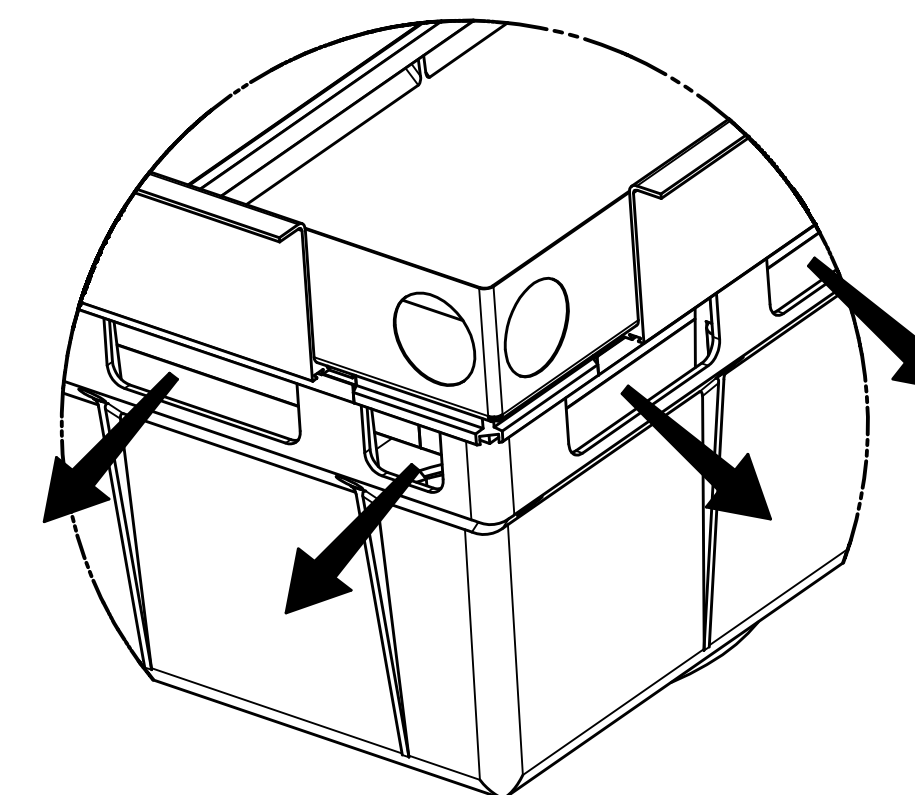
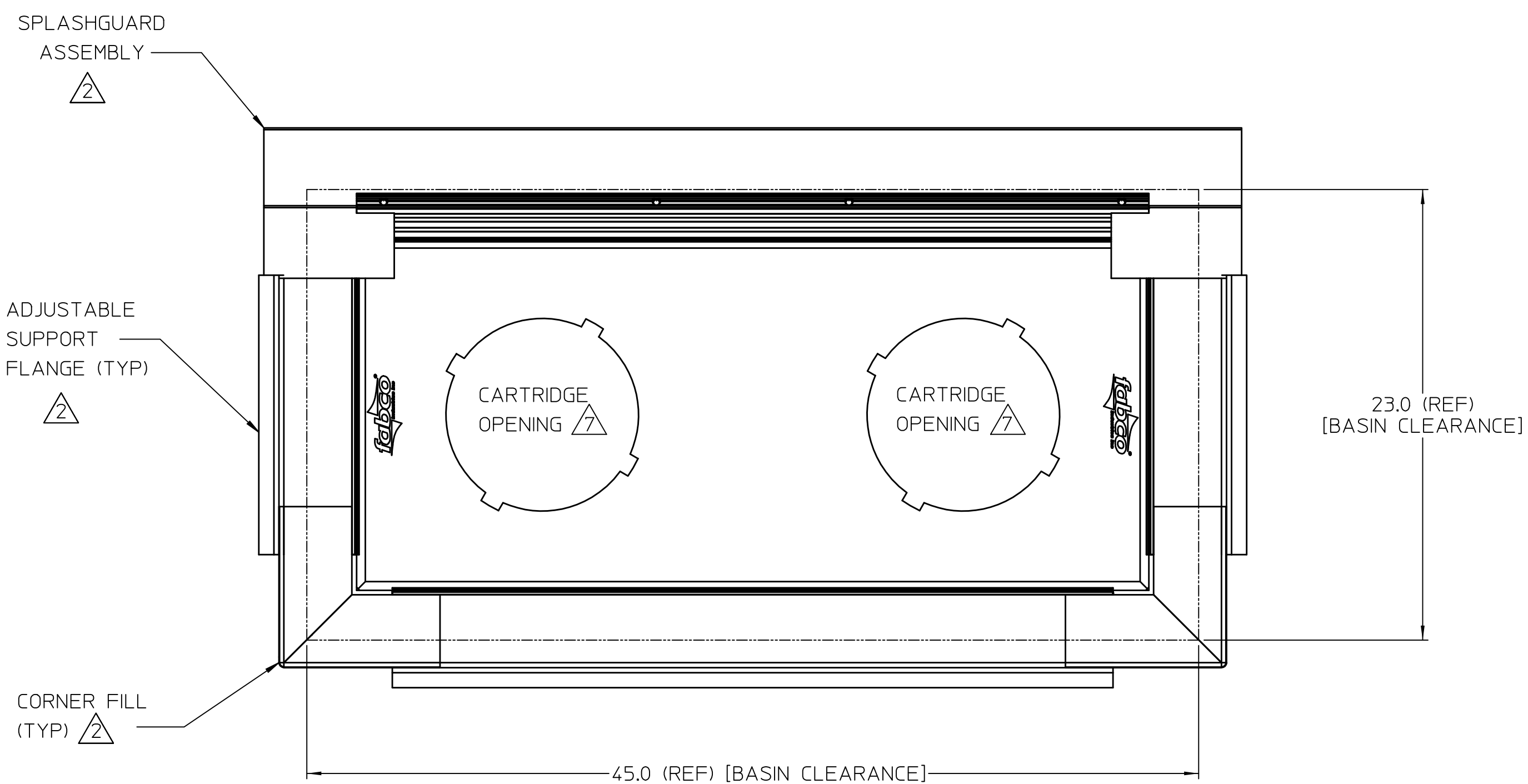

PROTECTED BYPASS, TYPICAL
(NOT TO SCALE)

COMBINATION GRATE
CLEAR OPENING DETAIL

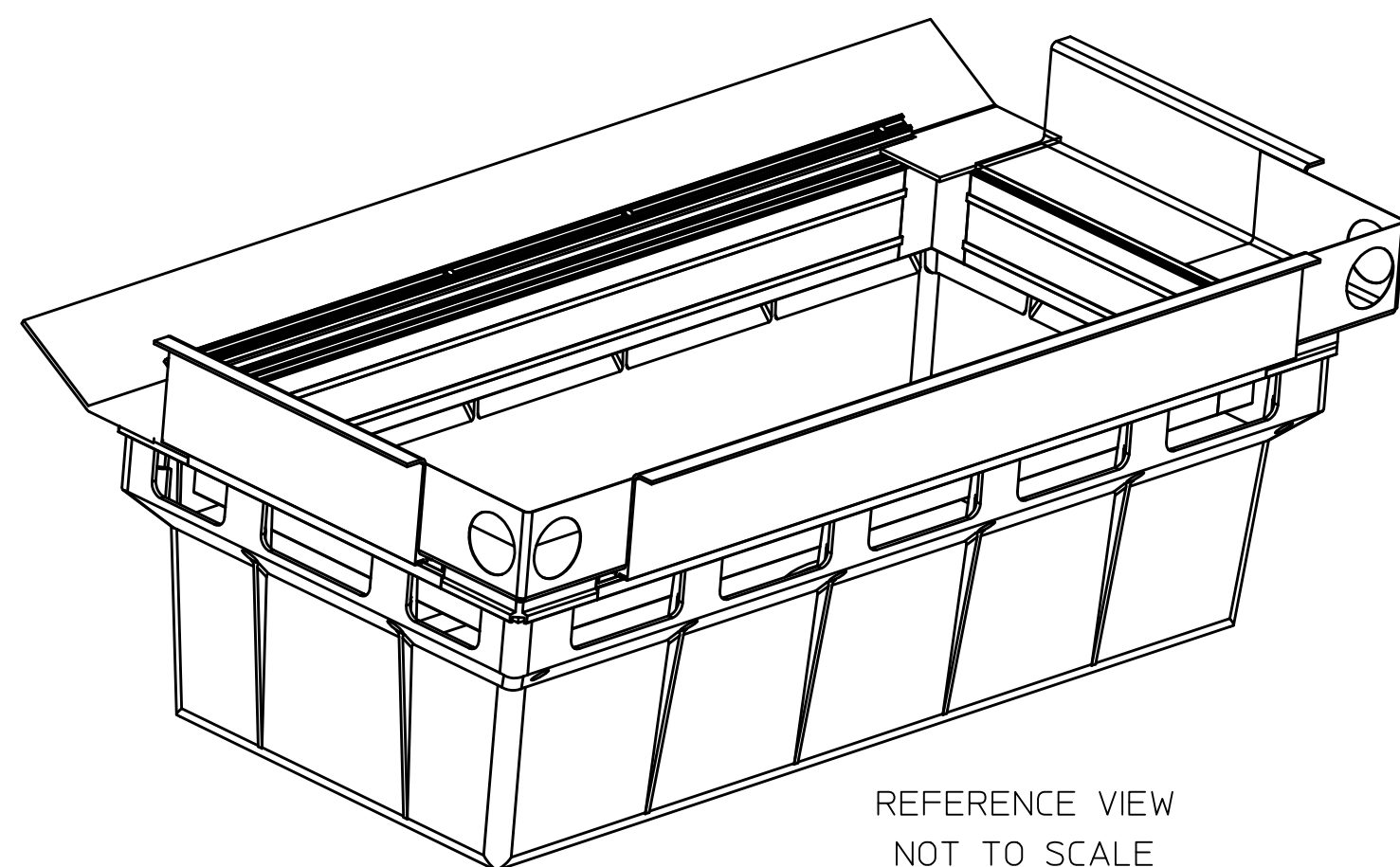
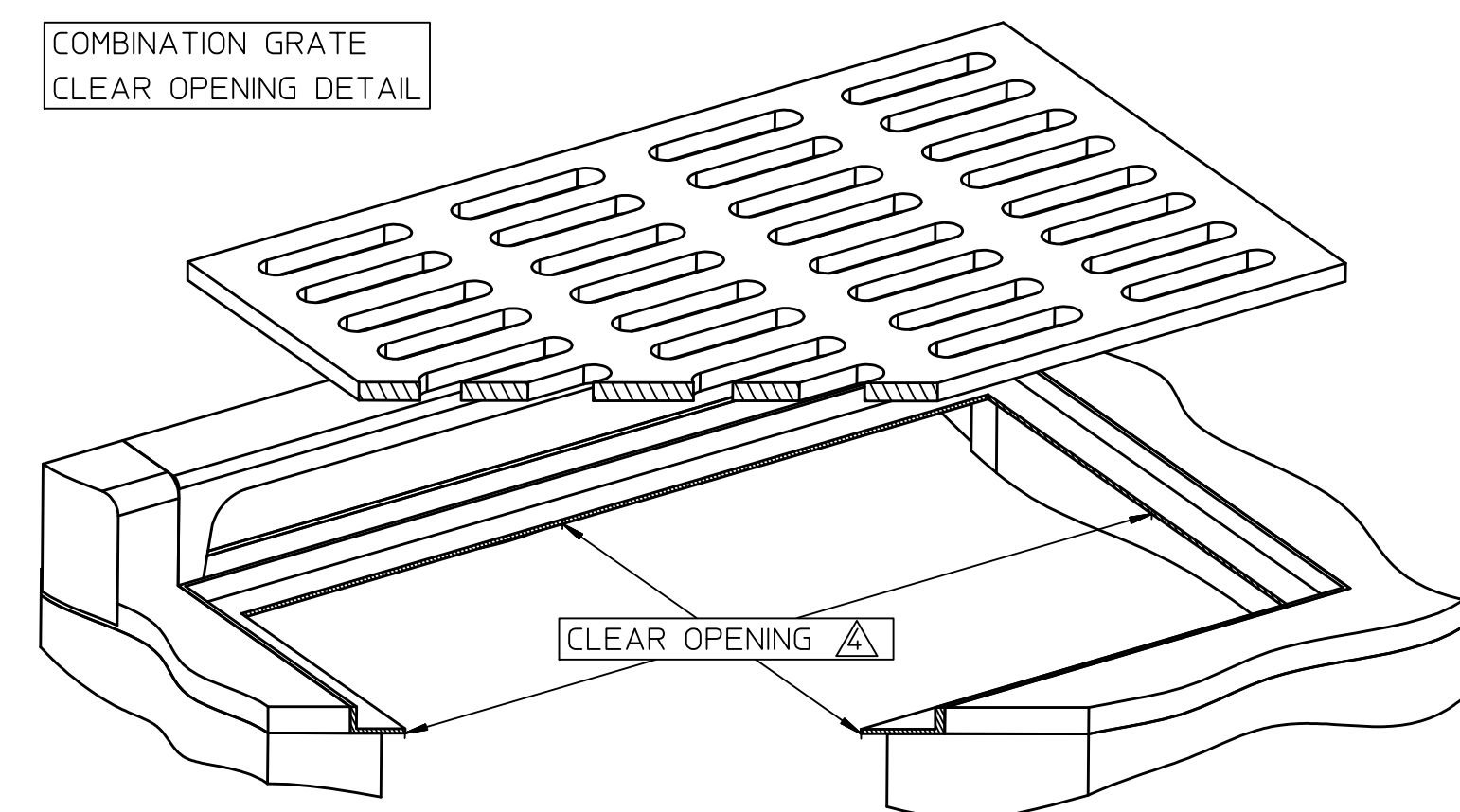

REFERENCE VIEW
NOT TO SCALE

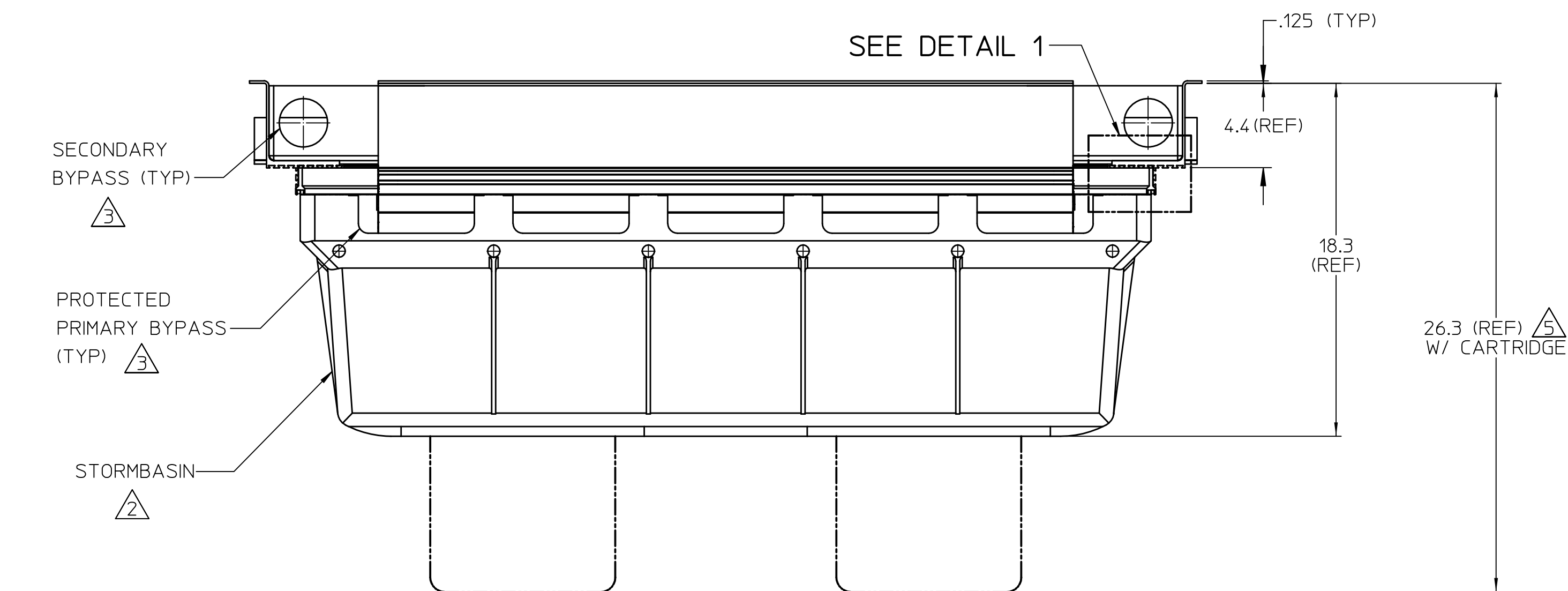

DOVETAIL ADJUSTMENT FEATURE
(TYPICAL EACH FLANGE)

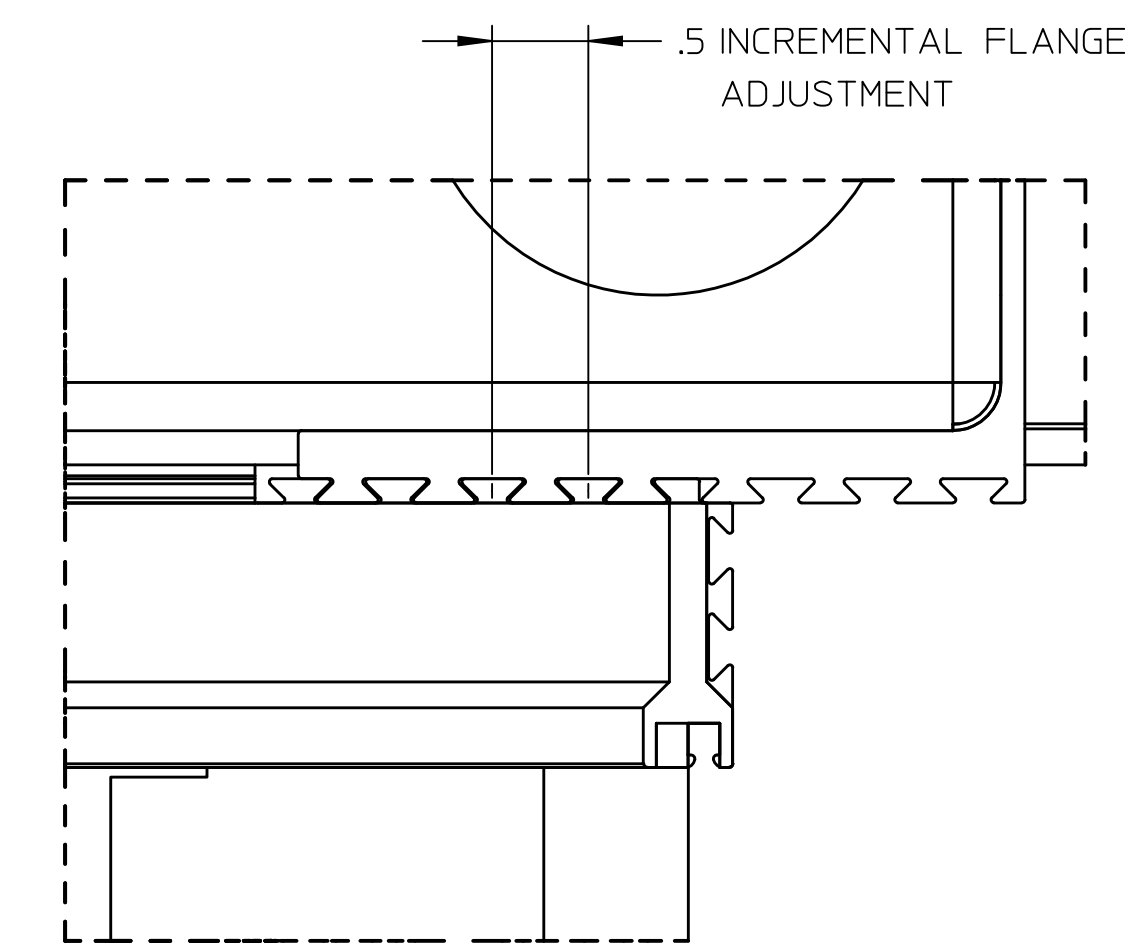

DETAIL 1
SCALE 1:1

NO	QTY	PART NUMBER	DESCRIPTION	REMARKS
BILL OF MATERIALS				
UNLESS OTHERWISE SPECIFIED: REMOVE ALL BURRS BREAK SHARP EDGES .002 - .020 FILLETS .020 MAX DIMENSIONS ARE IN INCHES AND INCLUDE CHEMICALLY APPLIED OR PLATED FINISHES DO NOT SCALE THIS DRAWING		TOLERANCES: DEC .00 ± .01 DEC .000 ± .005 FRACT ± 1/16 ANGLE ± 2° Ra FINISH 125		APPROVALS DATE DWN N.NEUWIRTH 06/14/06 CHKR R.MARSTON 5/25/11 ENGR J. PETERS 06/14/06
MATERIAL		SEE NOTES		APVD
MODEL LINK		9731-1E_ASSY3		FABCO INDUSTRIES, INC. 66 CENTRAL AVENUE FARMINGDALE, NY 11735 WWW.FABCO-INDUSTRIES.COM
TITLE		STORMBASIN, 23X45 CS		
SIZE	CAGE CODE	DWG NO	REV	
D	1P8A4	9731-1E-000	D	
SCALE 3/16		WT	SHEET 1 OF 1	